



HAIMISH
WINDOWS

About Us



- ❖ **Haimish Windows** is India's fastest growing uPVC Windows and Doors company Established in Pune.
- ❖ **Haimish Windows** is committed to deliver high quality Elite uPVC Windows , High end Aluminum Windows and other similar products.
- ❖ **Haimish Windows** is a part of **Alfa Façade Systems Pvt. Ltd.** is an established as aluminum fenestration company started from a humble beginning on 1st August 1998. Based in Pune, India, it has gathered rich & vast experience in manufacturing of aluminum architectural products such as doors, windows and facades.
- ❖ **Alfa Façade Systems** has expanded the product range and offering by introducing **Haimish Windows** with Technical Collaboration with **SALAMANDER-Germany**
- ❖ **SALAMANDER** is a global leader in the design and manufacture of high-quality systems for windows & doors as well as high-design building products.

Infrastructure



- ❖ Mastered the art of working on highly complex uPVC windows, aluminum and steel façades.
- ❖ Excellence is revealed by State of Art manufacturing facility that it operates in Burhani Industrial Estate ,Kondhva Pune.
- ❖ A state-of-Art factory which houses both its fabrication, assembling and powder coating facilities.
- ❖ Ready with efficient in-house Design Team using the latest CAD, 3D technologies that helps create the product lines prior to delivery and installation.
- ❖ End-to-end solutions and variety of glazing systems, which helps developers and architects give life to their vision

Technical Partner



SALAMANDER

WINDOW & DOOR SYSTEMS



uPVC Advantages

❖ Conserve

- ❖ Natural resource (Wood, air & Water) & Energy

❖ Enhance Product Life

- ❖ No termite, no painting

❖ Improve Living

- ❖ Aesthetic, Reduced Noise & Dust Ingress



Product & Range



Dark Oak



Mahogany



Walnut V

- ❖ Casement Windows
- ❖ Sliding Windows
- ❖ Tilt & turn Windows
- ❖ Bay Windows

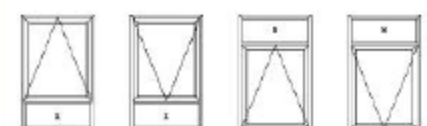
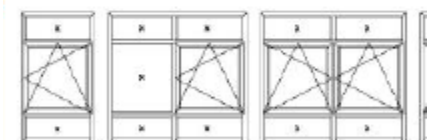
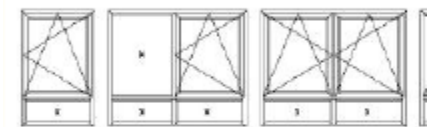
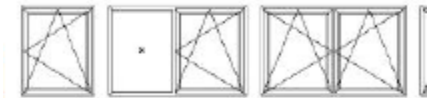
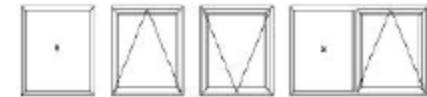
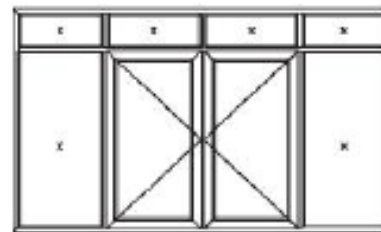
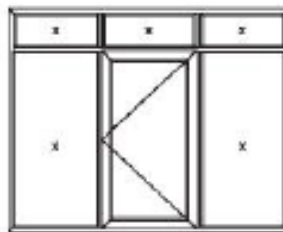
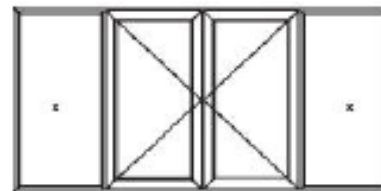
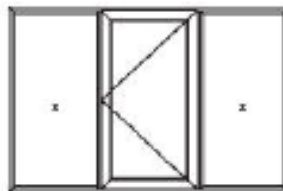
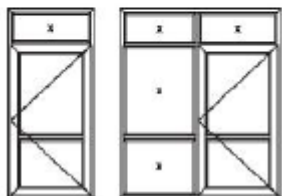
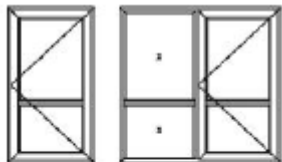
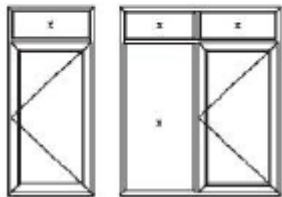
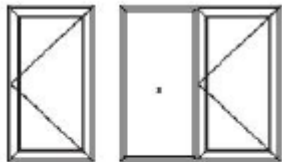

Product & Range

- ❖ Bi-Fold Door System
- ❖ Tilt & Slide System



Type 321

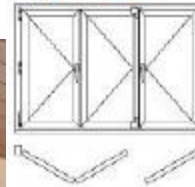

2 Folding Sashes
1 Main Opening Sash

Type 330

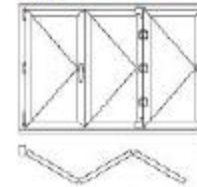

3 Folding Sashes
0 Main Opening Sash

Type 431

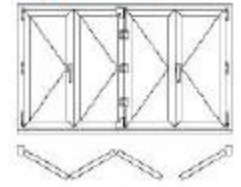

3 Folding Sashes
1 Main Opening Sash

Type 541

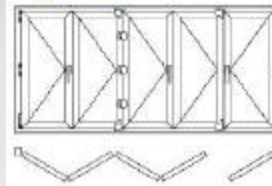

4 Folding Sashes
1 Main Opening Sash

Type 550

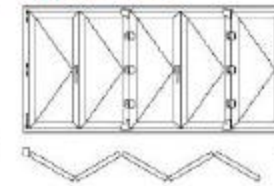

5 Folding Sashes
0 Main Opening Sash

Type 532

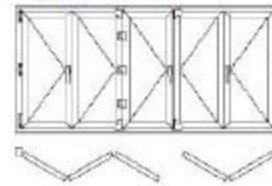

3+2 Folding Sashes
0 Main Opening Sash

Type 651

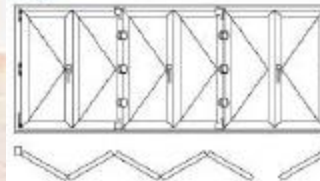

5 Folding Sashes
1 Main Opening Sash

Type 633

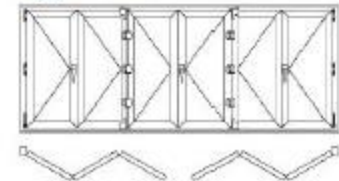

3+3 Folding Sashes
0 Main Opening Sash

Quality Supply Chain



Client need identification



Customized Solutions



Survey & Fabrication



Delivery and Installation



Cleaning & Handover



Customer Satisfaction

State of Art Infrastructure

- ❖ In House Fabrication
- ❖ ISO Certified



CNC Multi-Purpose Machine



Double Head Cutting Machine



Fabrication Floor



CNC Cutting Machine



Powder Coating Plant



M.S. & G.I. Sheet Cutting Machine

Quality Hardware



Design, size, color, glazing (single/double/triple), type of glass and hardware in harmony with the rest of your room

3 Chamber Section and GI Reinforcement

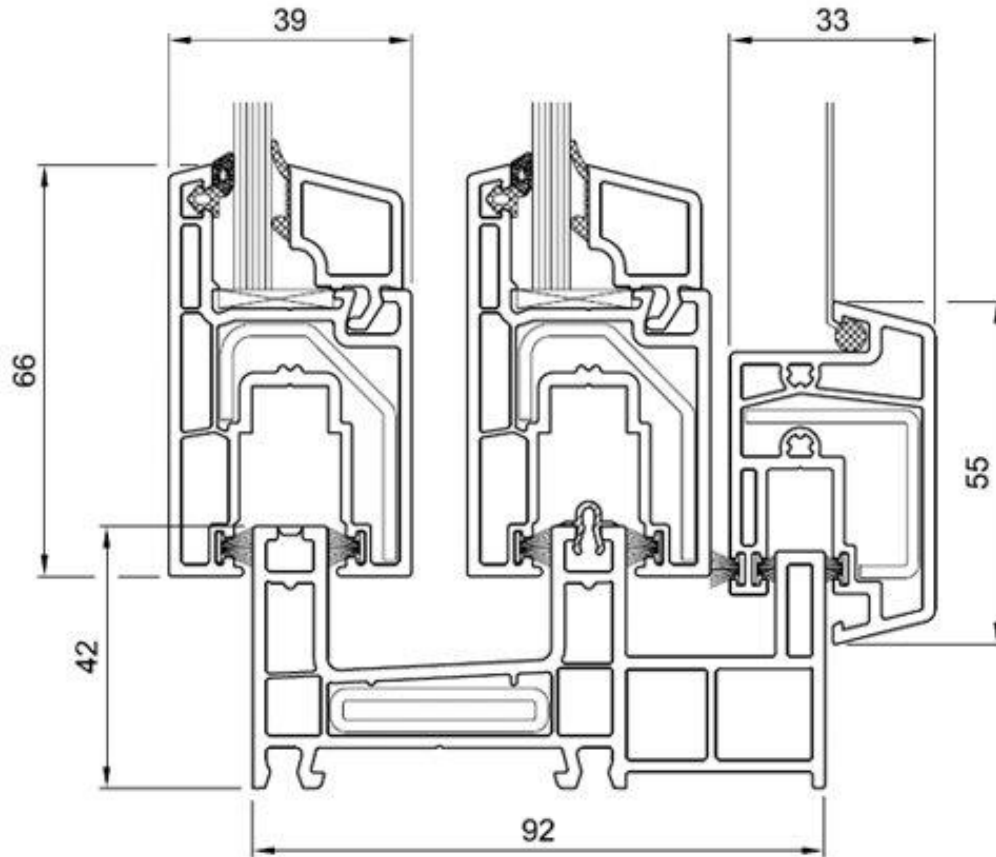

Installation by Qualified Teams

- ❖ Knowledgeable and Efficient Service Team
- ❖ Perfect Installation = Performance of the highest order
- ❖ Teams understand the importance of site hygiene
- ❖ Call Centre – at your service 365 days in the year

Partners and Membership



HAIMISH
WINDOWS

SALAMANDER
WINDOW & DOOR SYSTEMS



UWDMA
UPVC Window & Door
Manufacturers Association

Snapshot



- ❖ Pioneers and innovators
- ❖ Most preferred brand
- ❖ The only end-to-end solution
- ❖ Made to international standards
- ❖ World-Class service
- ❖ Certified technicians
- ❖ Efficient Sales and Service Network
- ❖ Call Centre – at your service 365 days in the year

Extra Benefits



- ❖ CAN SUSTAIN at highest Wind load
- ❖ Rattle Free
- ❖ Monsoon protection (windows preventing the water ingress)
- ❖ Excellent Sealing
- ❖ Single & multi-point locking options
- ❖ Seamless Design Flexibility, Large Window Spans
- ❖ Elegant looks

Our Clients



Our Clients



Our Projects



MAGARPATIA CITY



EMPIRE TOWER

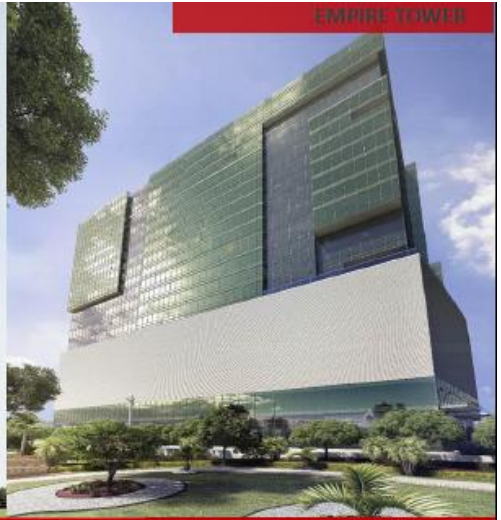

CONRAD HILTON



T5, T6, & T7 BROOKFIELD

Our Projects

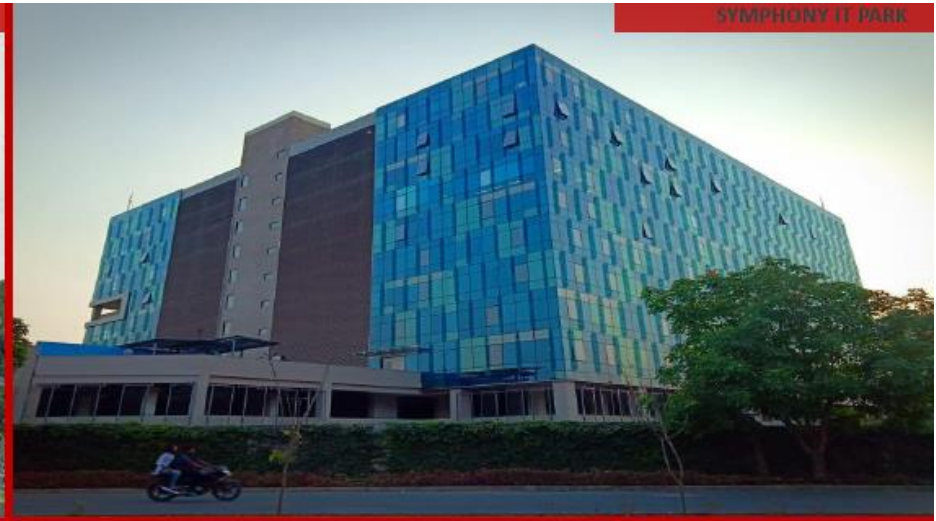

Our Projects



Our Projects

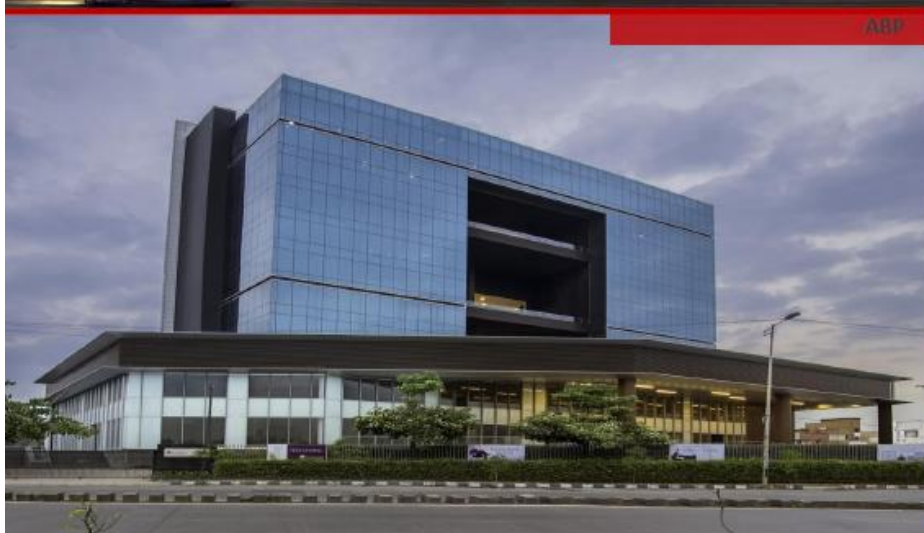

Promising Service Excellence



